

Description

The AP1501 is a fully integrated step-down DC/DC converter, with the ability to drive 3A load without the need of additional driver components. The AP1501 operates at a switching frequency of 150kHz enabling the use of small size filter components. As a result, board space is reduced and BOM costs are lowered.

The AP1501 has integrated the shutdown function that allows standby mode to be activated via an external logic signal input. The internal compensation facilitates feedback control for line and load regulation without the need of an external circuitry. The AP1501 has a built-in Thermal shutdown and Current Limit function to prevent damage from high operating temperature and high current operating to the output switch.

Additional features include a guaranteed +/- 4% tolerance on the output voltage under specified input and output load conditions, and +/- 15% on oscillator frequency. The AP1501 offers both fixed and adjustable output voltages. For fixed outputs the AP1501 supports 3.3V, 5.0V and 12V. The package options available are standard 5-lead TO263 and TO220(R) packages.

Features

- Output Voltage: 3.3V, 5V, 12V and Adjustable Output Version
- Adjustable Version Output Voltage Range, 1.23V to 37V+4%
- 150kHz +15% Fixed Switching Frequency
- Voltage Mode Non-Synchronous PWM Control
- Thermal-Shutdown and Current-Limit Protection
- ON/OFF Shutdown Control Input
- Operating Voltage can be up to 40V
- Output Load Current: 3A
- Low Power Standby Mode
- Built-In Switching Transistor on Chip
- TO263-5 and TO220-5(R) Packages
- **Totally Lead-Free & Fully RoHS Compliant (Notes 1 & 2)**
- **Halogen- and Antimony-Free. "Green" Device (Note 3)**

Notes:

1. No purposely added lead. Fully EU Directive 2002/95/EC (RoHS), 2011/65/EU (RoHS 2) & 2015/863/EU (RoHS 3) compliant.
2. See <https://www.diodes.com/quality/lead-free/> for more information about Diodes Incorporated's definitions of Halogen- and Antimony-free, "Green" and Lead-free.
3. Halogen- and Antimony-free "Green" products are defined as those which contain <900ppm bromine, <900ppm chlorine (<1500ppm total Br + Cl) and <1000ppm antimony compounds.

Pin Assignments

(Top View)

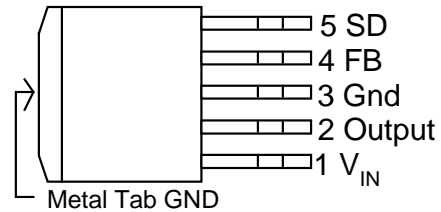

TO263-5L

(Top View)

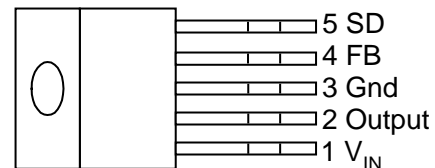

TO220-5L/TO220-5L(R)

Applications

- Simple High-Efficiency Step-Down Regulator
- On-Card Switching Regulators
- Positive to Negative Converter

Typical Applications Circuit

(1) Fixed Type Circuit

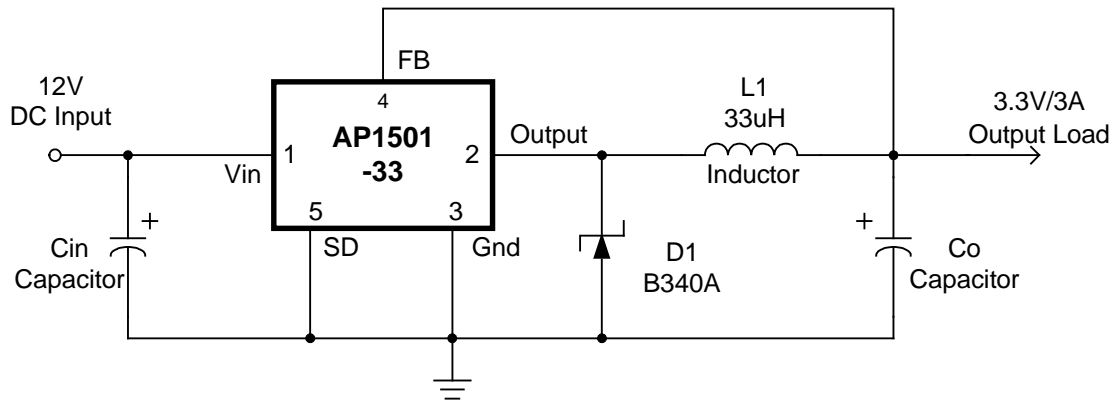

Typical Applications Circuit (continued)

(2) Adjustable Type Circuit

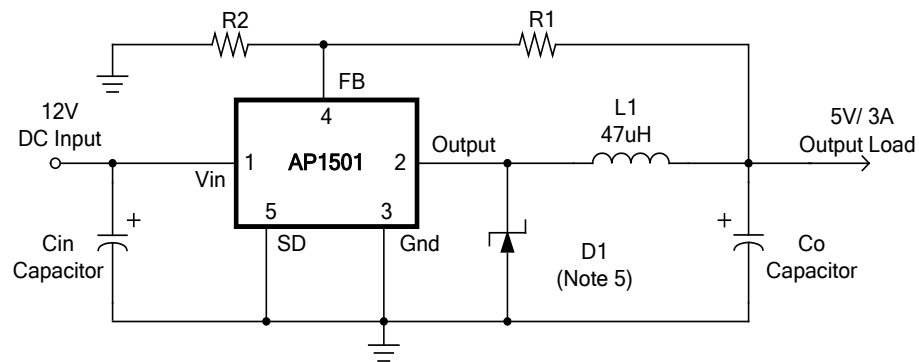

$$V_{out} = V_{FB} \times \left(1 + \frac{R1}{R2}\right)$$

$$V_{FB} = 1.23V$$

$$R2 = 1K \sim 3K$$

(3) Delay Start Circuit

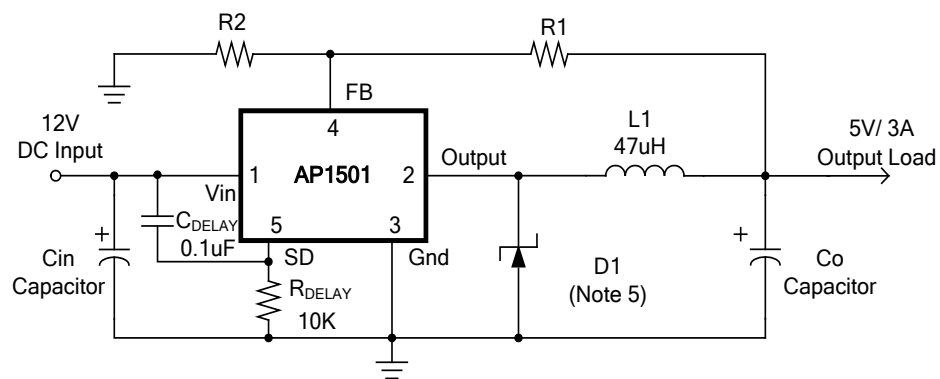

Note: Suggested Diodes Incorporated's Power Schottky: B340A or PDS340 series.

Pin Descriptions

Name	Description
V _{IN}	Operating Voltage Input
Output	Switching Output
Gnd	Ground
FB	Output Voltage Feedback Control
SD	ON/OFF Shutdown

Functional Block Diagram

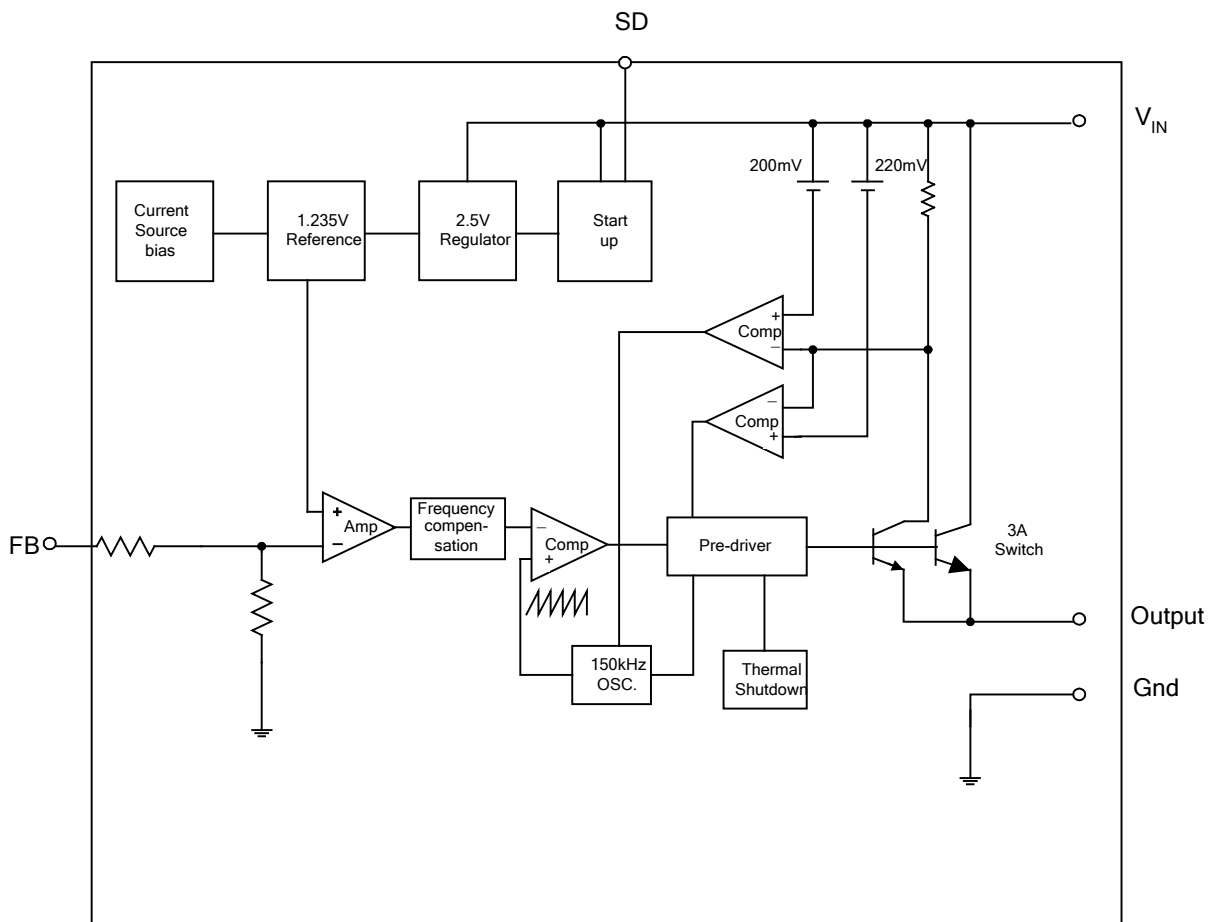

Absolute Maximum Ratings

Symbol	Parameter	Rating	Unit
ESD MM	Machine Model ESD Protection	400	V
V _{CC}	Supply Voltage	+45	V
V _{SD}	ON/OFF Pin Input Voltage	-0.3 to +40	V
V _{FB}	Feedback Pin Voltage	-0.3 to +40	V
V _{OUT}	Output Voltage to Ground	-1	V
P _D	Power Dissipation	Internally Limited	W
T _{ST}	Storage Temperature	-65 to +150	°C
T _J	Operating Junction Temperature	-20 to +125	°C
T _{MJ}	Maximum Junction Temperature	+150	°C

Electrical Characteristics (@ $T_A = +25^\circ\text{C}$, unless otherwise specified.)

Unless otherwise specified, $V_{IN} = 12\text{V}$ for 3.3V, 5V, adjustable version and $V_{IN} = 24\text{V}$ for the 12V version. $I_{LOAD} = 0.5\text{A}$
 Specifications with **boldface type** are for full operating temperature range, the other type are for $T_J = +25^\circ\text{C}$.

Symbol	Parameter		Conditions	Min	Typ.	Max	Unit
I_{FB}	Feedback Bias Current		$V_{FB} = 1.3\text{V}$ (Adjustable Version Only) (Note 4)	—	40	60	nA
						100	
F_{OSC}	Oscillator Frequency		—	127	150	173	kHz
				110	—	173	
V_{SAT}	Saturation Voltage		$I_{OUT} = 3\text{A}$ No Outside Circuit $V_{FB} = 0\text{V}$ Force Driver On	—	1.3	1.4	V
						1.5	
DC	Max. Duty Cycle (ON)		$V_{FB} = 0\text{V}$ Force Driver On	—	100	—	%
	Min. Duty Cycle (OFF)		$V_{FB} = 12\text{V}$ Force Driver Off	—	0	—	
I_{CL}	Current Limit		Peak Current No Outside Circuit $V_{FB} = 0\text{V}$ Force Driver On	3.6	4.0	5.5	A
						6.5	
I_L	Output = 0	Output Leakage Current	—	—	200	200	μA
	Output = -1		—	2	60	60	mA
I_Q	Quiescent Current		$V_{FB} = 12\text{V}$ Force Driver Off	—	5	10	mA
I_{STBY}	Standby Quiescent Current		ON/OFF Pin = 5V $V_{IN} = 40\text{V}$	—	150	250	μA
						350	
V_{IL}	ON/OFF Pin Logic Input Threshold Voltage		Low (Regulator ON)	—	1.3	0.6	V
V_{IH}			High (Regulator OFF)	2.0		—	
I_H	ON/OFF Pin Logic Input Current		$V_{LOGIC} = 2.5\text{V}$ (OFF)	—	15	25	μA
I_L	ON/OFF Pin Input Current		$V_{LOGIC} = 0.5\text{V}$ (ON)	—	0.02	5	
θ_{JA}	Thermal Resistance Junction to Ambient		TO263-5 (Note 5)	—	37	—	$^\circ\text{C/W}$
			TO220-5(R) (Note 5)	—	31	—	
θ_{JC}	Thermal Resistance Junction to Case		TO263-5 (Note 5)	—	6	—	$^\circ\text{C/W}$
			TO220-5(R) (Note 5)	—	5	—	

Notes: 4. Feedback pin removed from output and connected to 0V to force the output transistor switch ON. Feedback pin removed from output and connected to 12V for the 3.3V, 5V, and the ADJ. version, and 15V for the 12V version, to force the output transistor switch OFF.
 5. Test condition: Device mounted with copper area of approximately 3 in^2 , 1oz, no air flow.

Electrical Characteristics (continued) (@ $T_A = +25^\circ\text{C}$, unless otherwise specified.)

Specifications with **boldface type** are for full operating temperature range, the other type are for $T_J = +25^\circ\text{C}$.

—	Symbol	Parameter	Conditions	V _{Min}	Typ.	V _{Max}	Unit
AP1501-ADJ	V_{FB}	Output Feedback	$4.5V \leq V_{IN} \leq 40V$ $0.2A \leq I_{LOAD} \leq 3A$ V_{OUT} programmed for 3V	1.193 1.18	1.23	1.267 1.28	V
	η	Efficiency	$V_{IN} = 12V, I_{LOAD} = 3A$	—	73	—	%
AP1501-3.3V	V_{OUT}	Output Voltage	$4.75V \leq V_{IN} \leq 40V$ $0.2A \leq I_{LOAD} \leq 3A$	3.168 3.135	3.3	3.432 3.465	V
	η	Efficiency	$V_{IN} = 12V, I_{LOAD} = 3A$	—	73	—	%
AP1501-5V	V_{OUT}	Output Voltage	$7V \leq V_{IN} \leq 40V$ $0.2A \leq I_{LOAD} \leq 3A$	4.8 4.75	5	5.2 5.25	V
	η	Efficiency	$V_{IN} = 12V, I_{LOAD} = 3A$	—	80	—	%
AP1501-12V	V_{OUT}	Output Voltage	$15V \leq V_{IN} \leq 40V$ $0.2A \leq I_{LOAD} \leq 3A$	11.52 11.4	12	12.48 12.6	V
	η	Efficiency	$V_{IN} = 15V, I_{LOAD} = 3A$	—	90	—	%

Performance Characteristics

Typical Performance Characteristics
Normalized Output Voltage

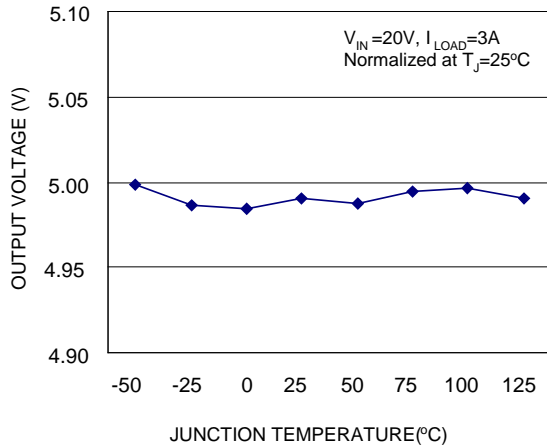

Efficiency

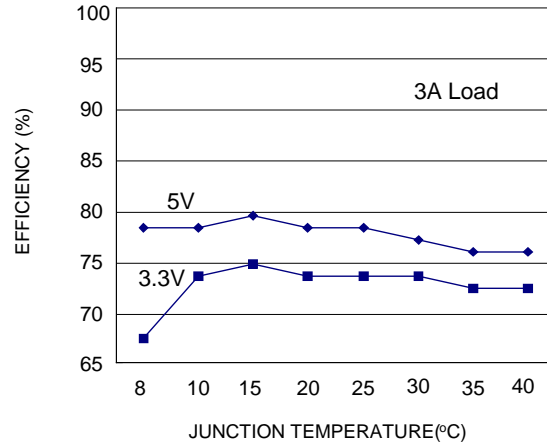

Switch Saturation Voltage

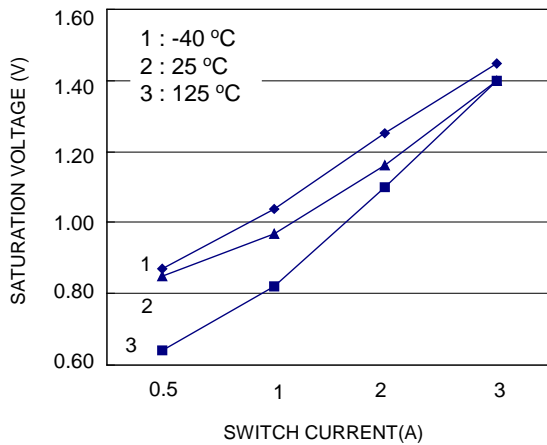

Switch Current Limit

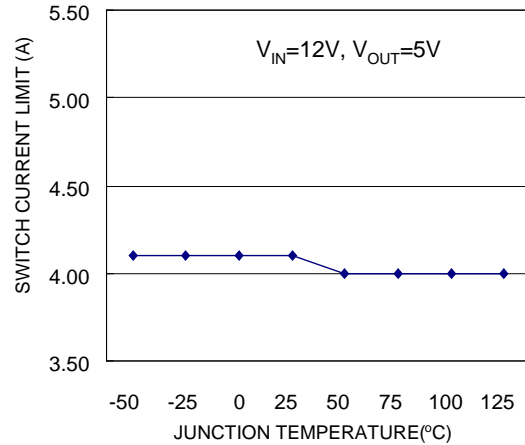

Operating Quiescent Current

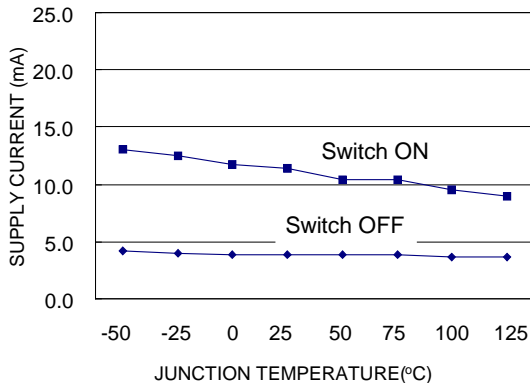

Shutdown Quiescent Current

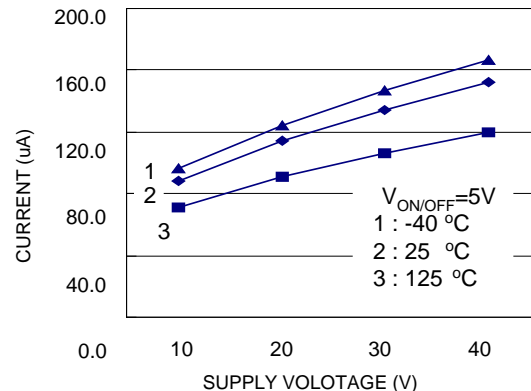

Performance Characteristics (continued)

Minimum Operating Supply Voltage

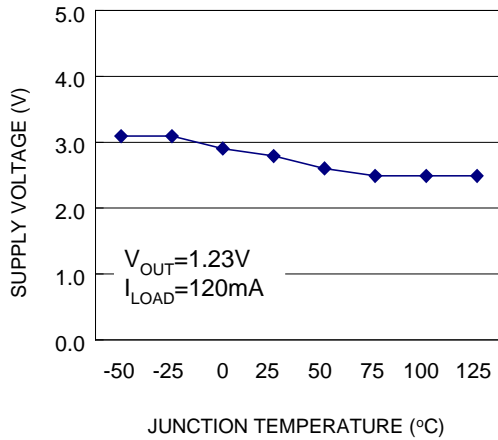

ON/OFF Threshold Voltage

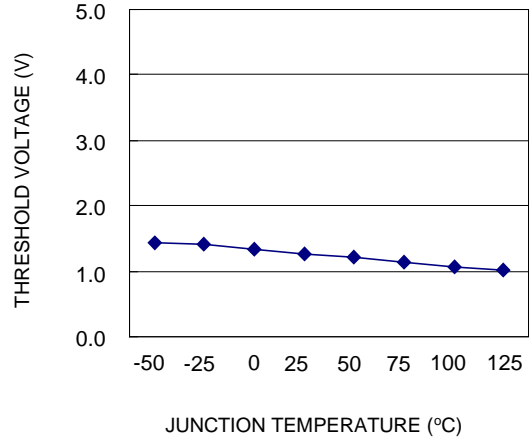

ON/OFF Pin Current (Sinking)

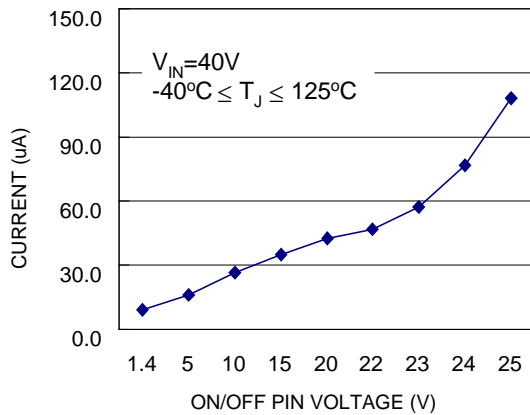

Switch Frequency

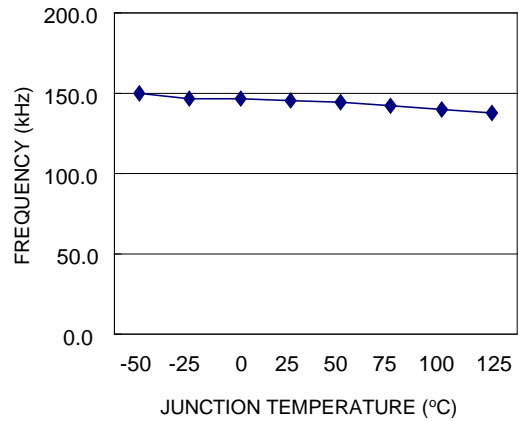

Feedback Pin Bias Current

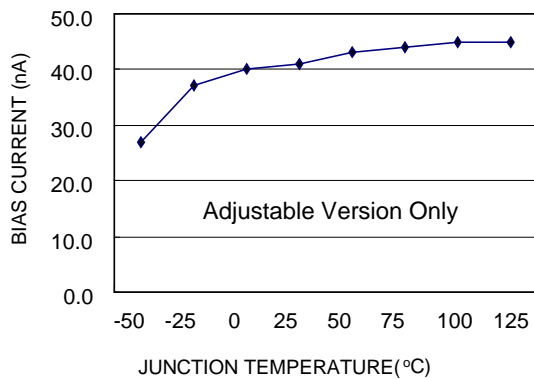

Ordering Information

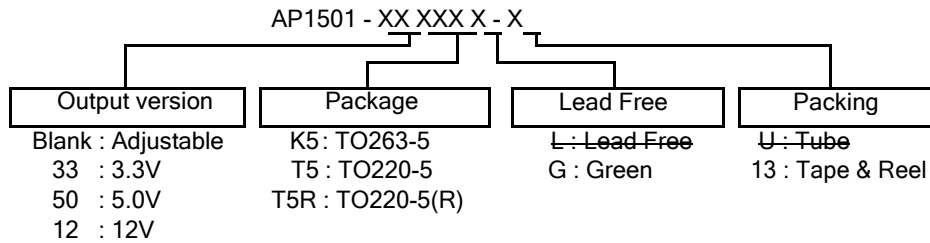

Device (Note 4)	Voltage	Package Code	Package (Note 7)	Lead Free/ Green	Quantity	Part Number Suffix		Status (Note 6)
						Tube	13" Tape and reel	
AP1501-50K5G-13	50	K5	TO263-5	Green	800	NA	-13	Active
AP1501-K5G-13	ADJ	K5	TO263-5	Green	800	NA	-13	Active
AP1501-12K5G-13	12	K5	TO263-5	Green	800	NA	-13	NRND
AP1501-33K5G-13	33	K5	TO263-5	Green	800	NA	-13	NRND

- Notes:
6. AP1501-50K5G-13 and AP1501-K5G-13 are Active. All other versions are NRND or EOL. For recommended alternatives to NRND/EOL devices, [Contact Us](#).
 7. For packaging details, go to our website at: <https://www.diodes.com/design/support/packaging/diodes-packaging/diodes-package-outlines-and-pad-layouts/>.

Operation Description

Pin Functions

+V_{IN}

This is the positive input supply for the IC switching regulator. A suitable input bypass capacitor must be present at this pin to minimize voltage transients and to supply the switching currents needed by the regulator.

Ground

Circuit ground.

Output

Internal switch. The voltage at this pin switches between (+V_{IN} – V_{SAT}) and approximately – 0.5V, with a duty cycle of approximately V_{OUT} / V_{IN}. To minimize coupling to sensitive circuitry, the PC board copper area connected to this pin should be kept a minimum.

Feedback

Senses the regulated output voltage to complete the feedback loop.

ON/OFF

Allows the switching regulator circuit to be shutdown using logic level signals thus dropping the total input supply current to approximately 150μA. Pulling this pin below a threshold voltage of approximately 1.3V turns the regulator on, and pulling this pin above 1.3V (up to a maximum of 40V) shuts the regulator down. If this shutdown feature is not needed, the ON/OFF pin can be wired to the ground pin or it can be left open, in either case the regulator will be in the ON condition.

Thermal Considerations

The AP1501 is available in 5-pin surface mount TO-263 and TO-220.

The TO-220 package needs a heat sink under most conditions. The size of the heat sink depends on the input voltage, the output voltage, the load current and the ambient temperature. The AP1501 junction temperature rises above ambient temperature for a 3A load and different input and output voltages. The data for these curves was taken with the AP1501 (TO-220 package) operating as a buck switching regulator in an ambient temperature of 25°C (still air). These temperature rise numbers are all approximate and there are many factors that can affect these temperatures. Higher ambient temperatures require more heat sinking.

The TO-263 surface mount package tab is designed to be soldered to the copper on a printed circuit board. The copper and the board are the heat sink for this package and the other heat producing components, such as the catch diode and inductor. The PC board copper area that the package is soldered to should be at least 0.4 in², and ideally should have 2 or more square inches of 2 oz. Additional copper area improves the thermal characteristics, but with copper areas greater than approximately 6 in², only small improvements in heat dissipation are realized. If further thermal improvements are needed, double sided, multilayer PC boards with large copper areas and/or airflow are recommended.

Operation Description (continued)

The AP1501 (TO-263 package) junction temperature rises above ambient temperature with a 2A load for various input and output voltages. This data was taken with the circuit operating as a buck switching regulator with all components mounted on a PC board to simulate the junction temperature under actual operating conditions. This curve can be used for a quick check for the approximate junction temperature for various conditions, but be aware that there are many factors that can affect the junction temperature. When load currents higher than 2A are used, double sided or multilayer PC boards with large copper areas and/or airflow might be needed, especially for high ambient temperatures and high output voltages.

For the best thermal performance, wide copper traces and generous amounts of printed circuit board copper should be used in the board layout. (One exception to this is the output (switch) pin, which should not have large areas of copper.) Large areas of copper provide the best transfer of heat (lower thermal resistance) to the surrounding air, and moving air lowers the thermal resistance even further.

Package thermal resistance and junction temperature rise numbers are all approximate, and there are many factors that will affect these numbers. Some of these factors include board size, shape, thickness, position, location, and even board temperature. Other factors are, trace width, total printed circuit copper area, copper thickness, single or double-sided, multilayer board and the amount of solder on the board. The effectiveness of the PC board to dissipate heat also depends on the size, quantity and spacing of other components on the board, as well as whether the surrounding air is still or moving.

Furthermore, some of these components such as the catch diode will add heat to the PC board and the heat can vary as the input voltage changes. For the inductor, depending on the physical size, type of core material and the DC resistance, it could either act as a heat sink taking heat away from the board, or it could add heat to the board.

Marking Information

(1) TO263-5

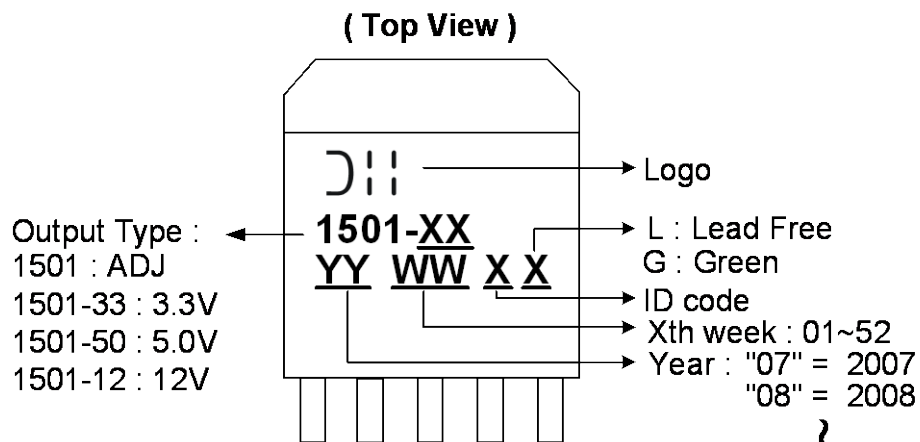

(2) TO220-5(R)

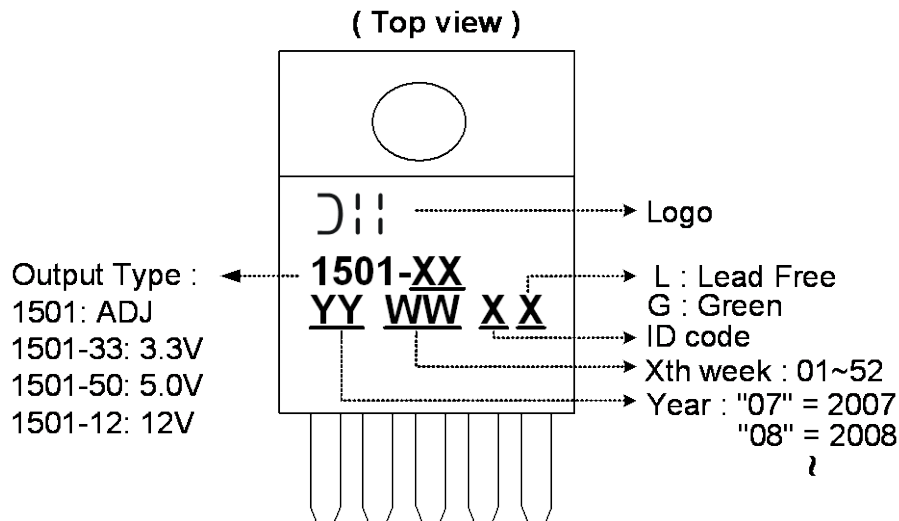

Package Outline Dimensions (All dimensions in mm.)

(1) Package Type: TO263-5

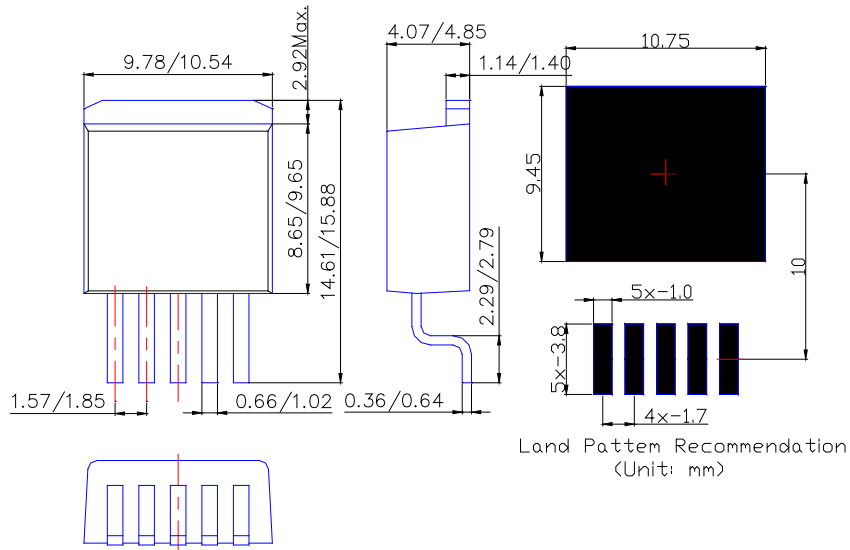

(2) Package Type: TO220-5

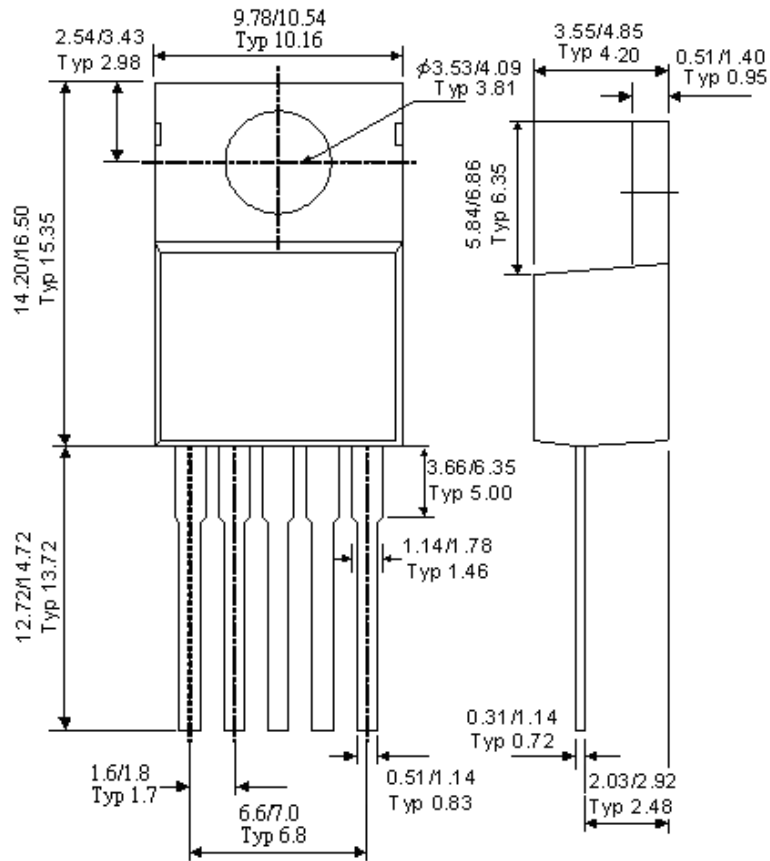

Package Outline Dimensions (All dimensions in mm.)

(3) Package Type: TO220-5(R) Mechanical drawing

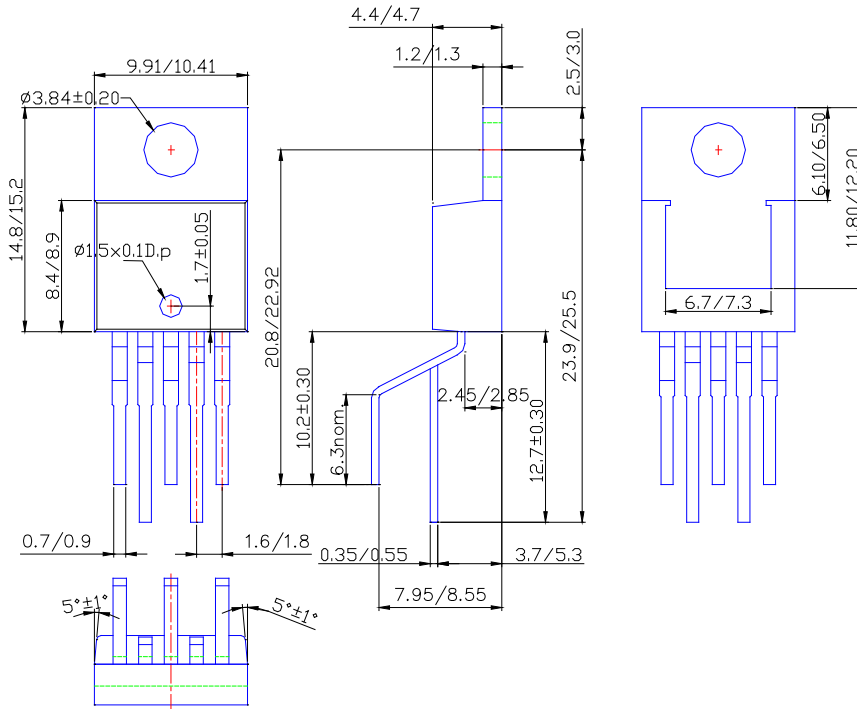

IMPORTANT NOTICE

DIODES INCORPORATED MAKES NO WARRANTY OF ANY KIND, EXPRESS OR IMPLIED, WITH REGARDS TO THIS DOCUMENT, INCLUDING, BUT NOT LIMITED TO, THE IMPLIED WARRANTIES OF MERCHANTABILITY AND FITNESS FOR A PARTICULAR PURPOSE (AND THEIR EQUIVALENTS UNDER THE LAWS OF ANY JURISDICTION).

Diodes Incorporated and its subsidiaries reserve the right to make modifications, enhancements, improvements, corrections or other changes without further notice to this document and any product described herein. Diodes Incorporated does not assume any liability arising out of the application or use of this document or any product described herein; neither does Diodes Incorporated convey any license under its patent or trademark rights, nor the rights of others. Any Customer or user of this document or products described herein in such applications shall assume all risks of such use and will agree to hold Diodes Incorporated and all the companies whose products are represented on Diodes Incorporated website, harmless against all damages.

Diodes Incorporated does not warrant or accept any liability whatsoever in respect of any products purchased through unauthorized sales channel. Should Customers purchase or use Diodes Incorporated products for any unintended or unauthorized application, Customers shall indemnify and hold Diodes Incorporated and its representatives harmless against all claims, damages, expenses, and attorney fees arising out of, directly or indirectly, any claim of personal injury or death associated with such unintended or unauthorized application.

Products described herein may be covered by one or more United States, international or foreign patents pending. Product names and markings noted herein may also be covered by one or more United States, international or foreign trademarks.

This document is written in English but may be translated into multiple languages for reference. Only the English version of this document is the final and determinative format released by Diodes Incorporated.

LIFE SUPPORT

Diodes Incorporated products are specifically not authorized for use as critical components in life support devices or systems without the express written approval of the Chief Executive Officer of Diodes Incorporated. As used herein:

A. Life support devices or systems are devices or systems which:

1. are intended to implant into the body, or
2. support or sustain life and whose failure to perform when properly used in accordance with instructions for use provided in the labeling can be reasonably expected to result in significant injury to the user.

B. A critical component is any component in a life support device or system whose failure to perform can be reasonably expected to cause the failure of the life support device or to affect its safety or effectiveness.

Customers represent that they have all necessary expertise in the safety and regulatory ramifications of their life support devices or systems, and acknowledge and agree that they are solely responsible for all legal, regulatory and safety-related requirements concerning their products and any use of Diodes Incorporated products in such safety-critical, life support devices or systems, notwithstanding any devices- or systems-related information or support that may be provided by Diodes Incorporated. Further, Customers must fully indemnify Diodes Incorporated and its representatives against any damages arising out of the use of Diodes Incorporated products in such safety-critical, life support devices or systems.

Copyright © 2020, Diodes Incorporated

www.diodes.com